

BUCKET CRUSHER MB: MUCH MORE THAN AN IDEA

MB: ONE LIKE NO ONE

The concept of the bucket crusher was born with us. With our unique and versatile product we have occupied an important space in the market of crushing.

WORLDWIDE



Our crusher has no limits! Our bucket crushers are actually in use at work sites all over the world from Europe, Africa, and the Middle-East to the American and Asian continents.

COMPLETE SCALE

Four models of bucket crushers satisfy all needs for a variety of applications.

HIGH TECHNOLOGY

The high performance of our bucket crushers is the result of the perfect integration of fine engineering and technology with rigorous constant quality control, which guarantees a long duration of our machines.

WE STAND BY YOU

Our crusher continues to evolve based upon communication with the customer. Enhancements are the result of feedback and innovative research aimed at the future of crushing.

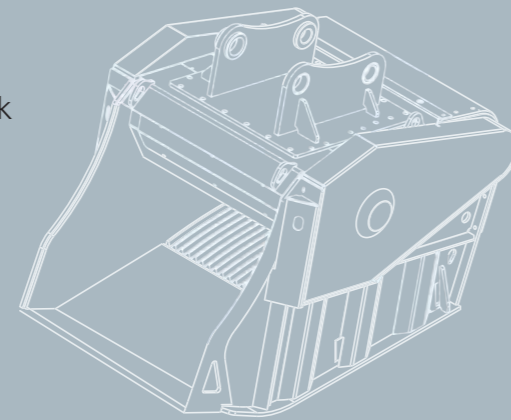

characteristics

www.mbcrusher.com

MB S.p.A.

Via Calcara, 11 Z.A. - 36042 Breganze (Vicenza) Italy
Tel. +39 0445 308148 - Fax +39 0445 308179
www.mbcrusher.com
info@mbcrusher.com

COMPANY WITH QUALITY MANAGEMENT
SYSTEM CERTIFIED BY DNV
= ISO 9001:2000 =

The data reported is not binding, inasmuch as the manufacturer reserves the right to make improvements on their products at any time without advance notice.

Rev. 2009-03

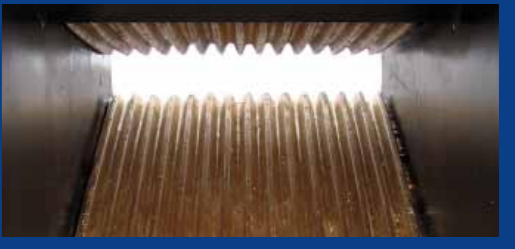

MB
THE CRUSHING EVOLUTION

crushing evolution

English

THE RIGHT SIZE FOR YOU



Whether for large or small work sites we make crushers for excavators starting from 8 tons. We'll help you to find the right one for your needs.

ON SITE REUTILIZATION



Pick up the materials and crush them directly on site. Our crushers increase your efficiency.

BREAK DOWN THE COSTS



Eliminating transportation and waste disposal costs means huge savings. With our bucket crushers, your work is more competitive.

APPLICATIONS

DEMOLITION - ROAD CONSTRUCTION - EXCAVATION - QUARRIES - ENVIROMENTAL REMEDIATION - VINEYARD DEEP-PLOWING



COMPANY CERTIFICATION ISO 14001 IN PROGRESS



efficient solutions

optionals

BF 60.1

Recommended for excavators ≥ 8 Ton.



BF 70.2

Recommended for excavators ≥ 14 Ton.

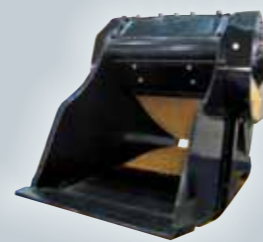

BF 90.3

Recommended for excavators ≥ 20 Ton.

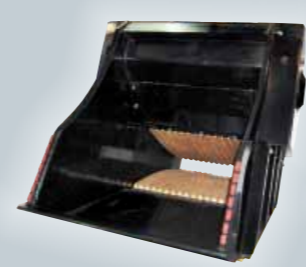

BF 120.4

Recommended for excavators ≥ 28 Ton.



product range

SPECIFICATIONS		BF 60.1	BF 70.2	BF 90.3	BF 120.4
RECOMMENDED EXCAVATOR	Tons	≥ 8	≥ 14	≥ 20	≥ 28
CAPACITY	m ³	0,50	0,60	0,75	1,00
BUCKET OPENING	mm	L.600 H.450	L.700 H.550	L.900 H.450	L.1200 H.450
OUTPUT ADJUSTMENT	mm	$\geq 20 <= 100$	$\geq 20 <= 120$	$\geq 20 <= 120$	$\geq 20 <= 120$
WEIGHT	Tons	1,5	2,25	3,5	4,9

ELECTROMAGNETIC IRON SEPARATOR FOR MB CRUSHER BUCKETS

The result of MB research, unique equipment, simple to install, comfortable to use



TECHNICAL SPECIFICATIONS

	IRON SEPARATOR KIT CODE	TOTAL WEIGHT	ATTRACTION EFFECT
BF 60.1	BF6010010	325 Kg.	150 mm
BF 70.2	BF7020010	340 Kg.	
BF 90.3	BF9030016	340 Kg.	
BF 120.4	BF1240008	365 Kg.	

- easy installation on the crusher bucket: (only BF 70.2 and 60.1 need a little drilling work on the rear part of the bucket).
- installation of the electrical system on the processing machinery is at the expense of the client. We recommend using a specialized technician (vehicle electrician).

SUPPLYING KIT

- MB S.p.A. supply the magnet, the magnet support and the installation kit to the client.

PRODUCTION OF AVERAGE TOUGHNESS MATERIAL (under ideal conditions)

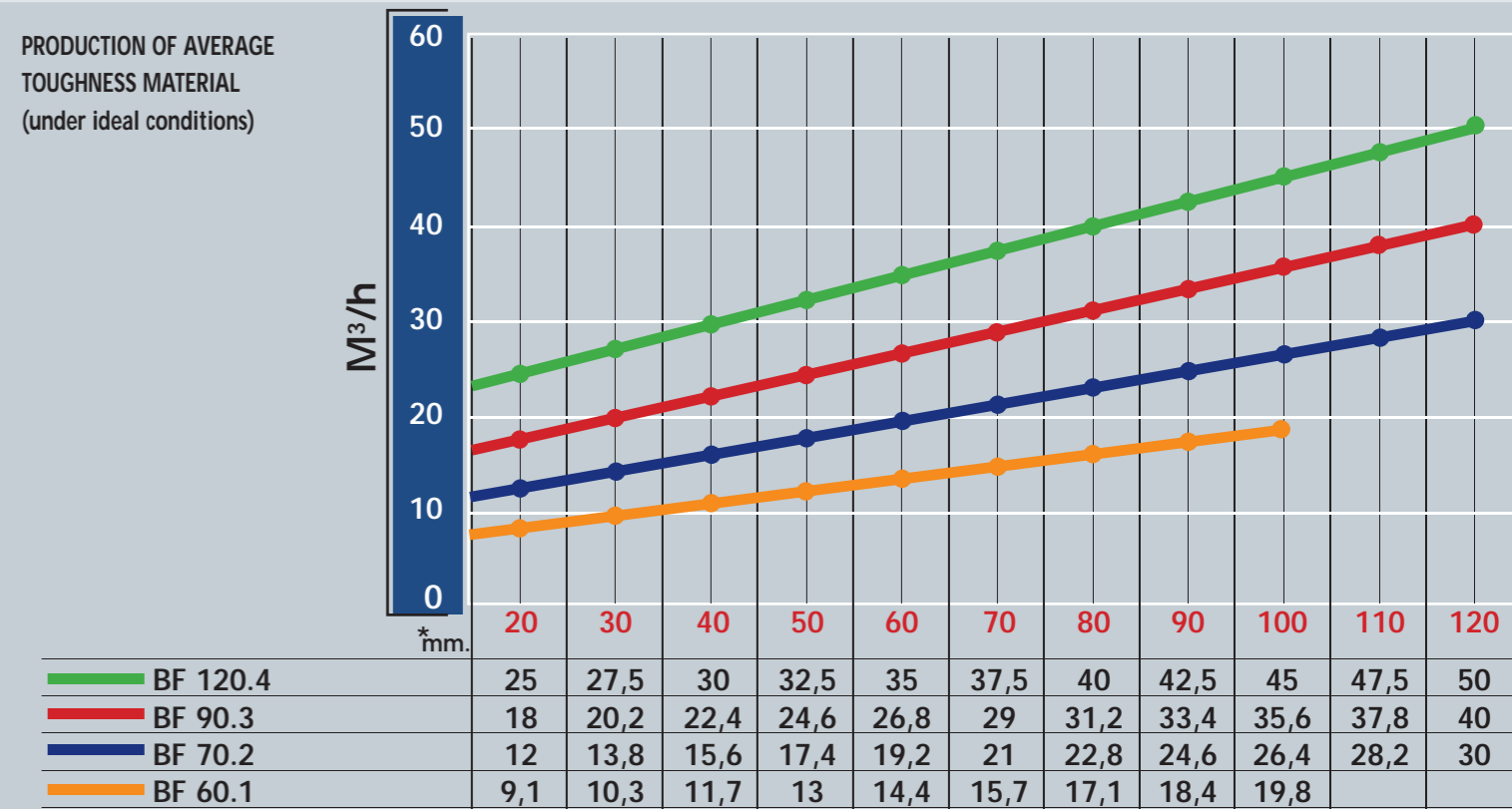

*output adjustment in mm